

Proliphix EPA-20 and EPA-60 Installation Guide

Release 1.0



P R O L I P H I X

Part No. 600-01004-000, Rev. 2
April 2008

Technical Support

When contacting Proliphix, Inc. for technical assistance, please have the following information available:

- Product model and serial number.
- Type of heating/cooling system (example: gas, oil, or electric; warm air, hot water, heat pump, steam or gravity).
- Location and number of wires attached to your Proliphix thermostat.

For additional assistance, please contact Proliphix, Inc. Technical Support, 9:00 AM to 5:00 PM Eastern Standard Time Monday to Friday:

Web: www.Proliphix.com
Email: support@Proliphix.com
Telephone: 1-866-IPLIVING
Fax: 978-692-3378

Warranty Information

Proliphix, Inc. warrants its products to be free from manufacturing defects in materials and workmanship under normal use for a period of 1 year for Professional and Basic Series Thermostats, Thermal Management Network Thermostats, Ethernet Power Adapters and Thermal Sensors from the date of purchase.

Proliphix shall not be liable to honor the terms of this warranty if the product has been used in any other application other than that for which it was intended, or if it has been subjected to misuse, accidental damage, acts of God, modification, or improper installation procedures. Furthermore, this warranty covers only products which have all original and unaltered markings and labels (serial numbers, model numbers, etc.) of manufacture. This limited warranty does not cover the repair of cracked, scratched, broken or modified plastics; other cosmetic damage; or parts that have been altered, defaced or removed; or the scratching, cracking or breakage of the product.

This warranty is not transferable.

THE FOREGOING WARRANTIES ARE THE SOLE AND EXCLUSIVE WARRANTIES EXPRESS OR IMPLIED GIVEN BY PROLIPHIX IN CONNECTION WITH THE PRODUCT, AND PROLIPHIX DISCLAIMS ALL IMPLIED WARRANTIES, INCLUDING IMPLIED WARRANTIES OF MERCHANTABILITY, FITNESS FOR A PARTICULAR PURPOSE AND NONINFRINGEMENT OF THIRD PARTY RIGHTS. PROLIPHIX DOES NOT PROMISE THAT THE PRODUCT IS ERROR-FREE OR WILL OPERATE WITHOUT INTERRUPTION. PROLIPHIX WILL NOT BE LIABLE FOR INCIDENTAL OR CONSEQUENTIAL DAMAGES OR FOR ANY OTHER LOSSES, EXPENSES OR DAMAGES RELATING TO PRODUCT DEFECTS OR FAILURES. CUSTOMER'S SOLE REMEDY, AND PROLIPHIX'S SOLE OBLIGATION, WITH RESPECT TO ANY PRODUCT DEFECTS OR FAILURES (REGARDLESS OF WHETHER YOUR CLAIM IS ASSERTED IN CONTRACT, TORT, STRICT LIABILITY OR OTHERWISE) SHALL BE (AT PROLIPHIX'S SOLE OPTION) REPAIR, REPLACEMENT OR REFUND OF THE PRICE PAID. IN NO EVENT WILL PROLIPHIX'S LIABILITY WITH RESPECT TO A PRODUCT, EXCEED THE PRICE PAID FOR SUCH PRODUCT.

This warranty statement supersedes all previous warranties.

This warranty extends to products purchased directly from Proliphix or an authorized Proliphix agent, dealer, distributor, or reseller.

**Material
Return
Procedure**

No merchandise may be returned for credit, exchange, or service without prior authorization from Proliphix. To obtain warranty service for Proliphix products, contact Proliphix Customer Service (1-866-475-4846) and request a Return Material Authorization (RMA) number.

Products may be returned for credit, exchange, or service with a Proliphix RMA number and with proof of purchase. Enclose a note explaining the symptoms of the problem, stating the RMA number, and the name, address and phone number of the company or individual contact.

Authorized returns must be shipped prepaid to Proliphix at:

Proliphix, Inc.
66 Tadmuck Road
Suite #1
Westford, MA 01886

The RMA number must be clearly marked on the outside of the package. Products received without an RMA number or without shipping prepaid will be subject to refusal by Proliphix. Proliphix reserves the right to charge a 15% restocking fee plus shipping costs on any products returned without an RMA.

Return shipping charges following repair of items under warranty shall be paid by Proliphix via standard ground carrier. In the event that repairs are found to be non-warranty, return shipping charges will be paid by the purchaser.

FCC

Model: NT10e/NT20e, NT100e/h, NT120e/h, NT130e/h, NT150e/h, NT160e/h, TM220e/h, and TM250e/h
EPA: EPA-20 and EPA-60
Made in the USA

This device complies with Part 15 of the FCC Rules. Operation is subject to the following two conditions: (1) this device may not cause harmful interference, and (2) this device must accept any interference received, including interference that may cause undesired operation.

CSA

Power: 24VAC 45mA 60Hz
48VDC 22mA 60Hz
Switched power each contact: 24VAC 2A 60Hz



Overview

The Proliphix EPA-20 and EPA-60 Installation Guide describes how to install the Proliphix Ethernet Power Adapter 20 (EPA-20) and Ethernet Power Adapter 60 (EPA-60).

Before you Begin

Before you can install the EPA-20 and EPA-60, you must:

- Determine a suitable location for the adapter, preferably near the Network switch or router.
- Verify a CAT5, CAT5E, or CAT6 cable is installed between the adapter and the Proliphix thermostat.



Caution

The EPA-20 and EPA-60 should only be powered with the Proliphix power supply included with the EPA-20 and EPA-60. Do not power the EPA-20 or EPA-60 with any other power supply.



Note

You can attach up to two Proliphix thermostats to a single EPA-20 adapter and up to six Proliphix thermostats to a single EPA-60 adapter.

Installing the EPA-20 and EPA-60

The following tools are required to install the EPA-20 and EPA-60:

- #2 Phillips head screwdriver
- 110 punch down tool, included

Mounting and Wiring the EPA-20 and EPA-60

This section describes how to mount and wire the EPA-20 and EPA-60.

- 1 Remove the adapter from packaging.
- 2 Mount the adapter with 1" screws provided.



Note

If the adapter is being installed on wallboard then anchors may be necessary.

- 3 Strip the end of the CAT5, CAT5E, or CAT6 cable sheathing approximately 1 ½".

- 4 Untwist the wire pairs.



Do not strip individual wires.



The 110 terminal and RJ-45 ports with the same number are part of the same connection. The connection is from the thermostat backplate into the EPA then continues from the RJ-45 to the network (router, switch, etc.).



*You **MUST** use the T568A wiring scheme on the thermostat backplate when connecting to the EPA. The EPA 110 block is wired as a T568A terminal, so both ends of the same wire must use the same scheme.*

- 5 Attach the other end of the CAT5, CAT5E, or CAT6 cable to the Proliphix thermostat.
 - Refer to [Figure 1](#) to wire the EPA-20.
 - Refer to [Figure 2](#) to wire the EPA-60.



You must verify the appropriate wires are placed in the correct pin holes on the adapters' punch down terminal.

Figure 1 EPA-20 Wiring

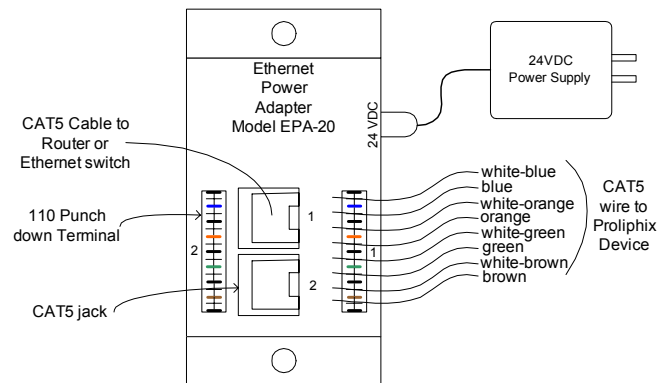
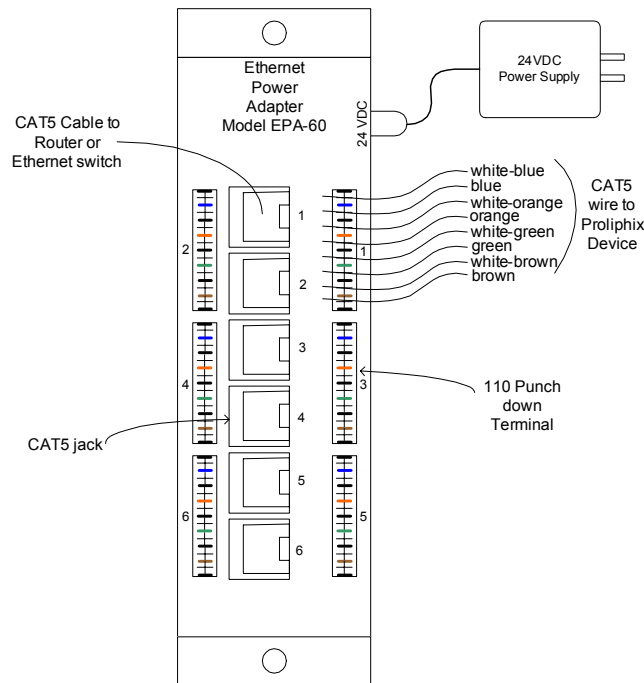

Figure 2 EPA-60 Wiring



- 6 Use a 110 punch down tool and punch each wire to one of the thermostat's punch down terminal pins. Refer to [Figure 1](#) and [Figure 2](#).
- 7 Match the adapter's CAT5, CAT5E, or CAT6 Jack port(s) to the corresponding punch down terminal port(s).
- 8 Plug a CAT5, CAT5E, or CAT6 patch cable from the adapter's CAT5, CAT5E, or CAT6 Jack port(s) to a router or Ethernet switch.



Note

The patch cable should be a straight through cable.



Caution

Do not apply power until the Proliphix thermostat is attached to the other end of the CAT5, CAT5E, or CAT6 cable(s). Plug the 24VDC power supply into the adapter which supplies power to the Proliphix thermostat attached to the adapter.

